

# PRODUCT DATA SHEET

## ET2143 Medium Speed Torquemeter

### Model Rating

Maximum Continuous Torque: 1400Nm

Maximum Continuous Speed: 2200rpm

Shaft Rating Range 140Nm to 1400Nm

Accuracy at Full Scale Torque 0.12% Application Dependant

### Specification

Number of Bearings	4
Bearing Temp. Quantity	1 Per Bearing
Bearing Temp. Monitoring	See GDS01
Bearing Lubrication Type	Grease
Accelerometer Mounting	2-off Each End. See GDS01
Rotastat Voltage	See GDS01

### Environment

Storage Temperature	-50 to 85°C
Operating Temperature	-20 to 80°C



### Outline Drawing

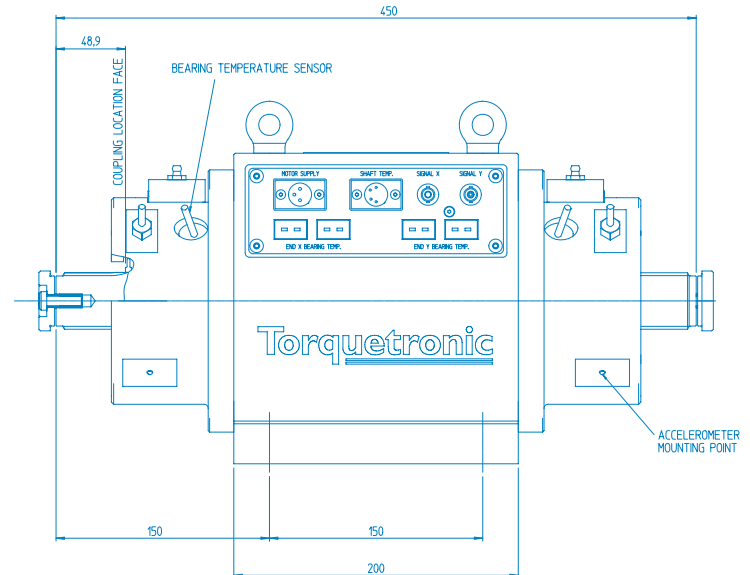
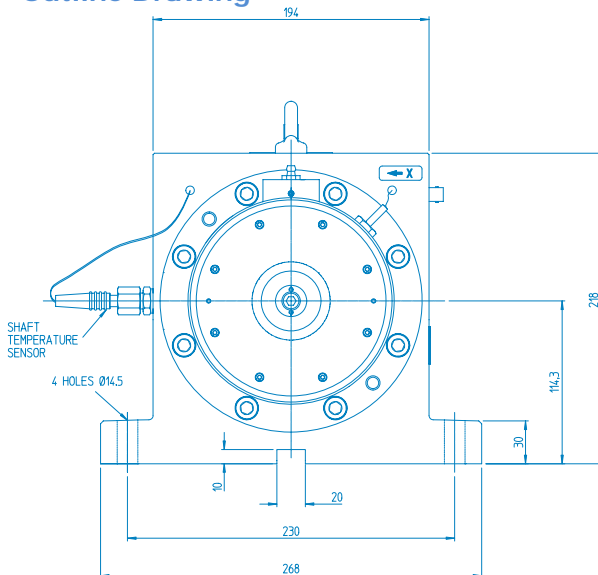

Overall Weight 45kg

For more detail see drawings

INST02-2143-00	For installation drawing
02-2143-00	For itemized assembly drawing
E850001	For typical electrical connection drawing



**Torquemeters Limited**  
 Ravensthorpe, Northampton, NN6 8ET, United Kingdom.  
 Telephone: +44 (0)1604 770232 Fax: +44 (0)1604 770778  
 email: info@torquemeters.com www.torquemeters.com

**Torquemeters** LIMITED  
 high performance test & measurement systems

03-2145-00	For drawing of optional calibration tooling
06-2145-00 & 06-2145-01	For optional bearing removal and refitting tooling

### Coupling Specification

Recommended Coupling	TORDISC LM214
Shaft End Type	Splined DIN 5480 - 40 x 2 x 18 x 7H 8f
Shaft Nominal Diameter	40mm

### Bearing Lubrication Requirements

Lubrication type	Synthetic Grease
Grease type	Lubcon L182 Grease
Grease quantity	1.1 ml

### Cartridge Style

Interchangeable torsion shafts for ET2143 supplied with bearings as a cartridge assembly

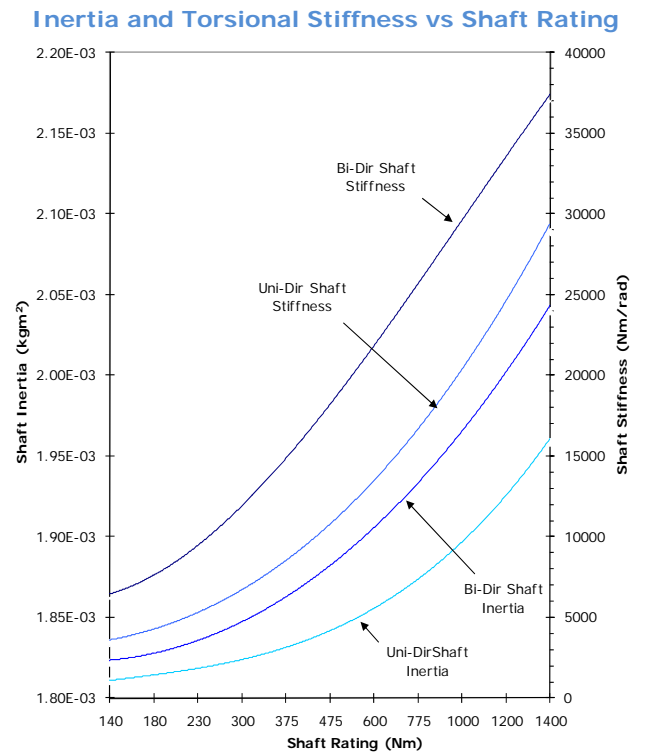
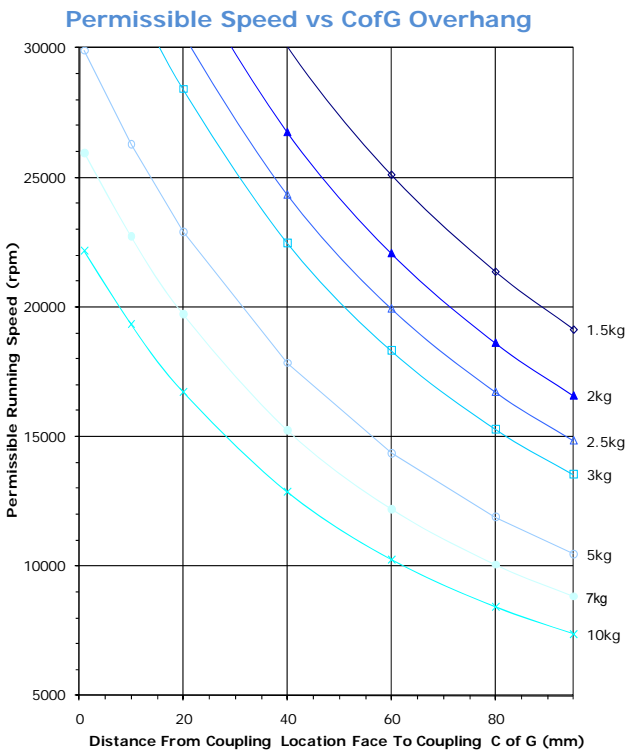

Please refer to Technical Data Sheet (TDS01) for details of Torquetric Torquemeter phase shift system.

Please refer to Generic Data Sheet (GDS01) for details of Torquemeter options.