

PRODUCT DATA SHEET

ET2303 Medium Speed Torquemeter

Model Rating

Maximum Continuous Torque: 3000Nm

Maximum Continuous Speed: 18000rpm

Shaft Rating Range 270Nm to 3000Nm

Accuracy at Full Scale Torque 0.12% Application Dependant

Specification

Number of Bearings	4
Bearing Temp. Quantity	1 Per Bearing
Bearing Temp. Monitoring	See GDS01
Bearing Lubrication Type	Grease
Accelerometer Mounting	2-off Each End. See GDS01
Rotastat Voltage	See GDS01

Environment

Storage Temperature	-50 to 85°C
Operating Temperature	-20 to 80°C



Outline Drawing

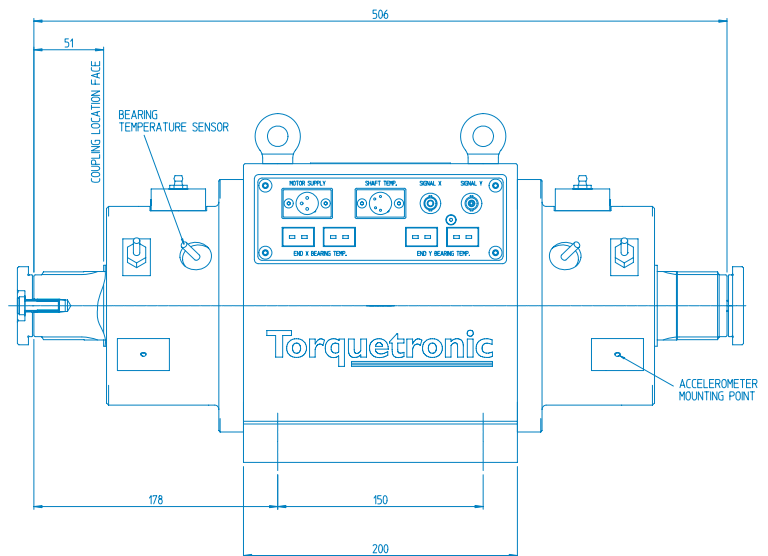
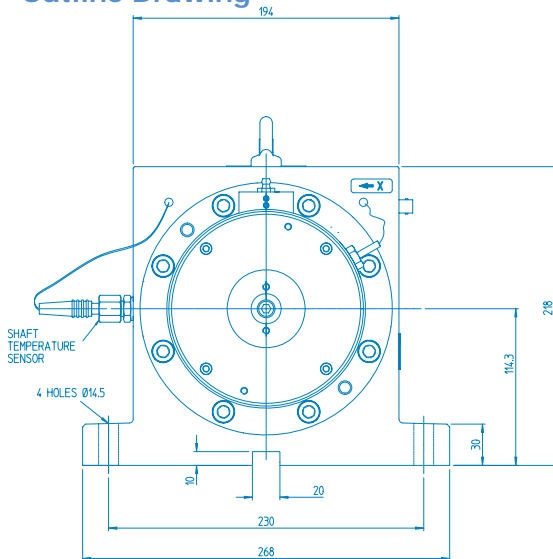

Overall Weight 50kg

For more detail see drawings

INST02-2303-00	For installation drawing
02-2303-00	For itemized assembly drawing
E850001	For typical electrical connection drawing
03-2303-00	For drawing of optional calibration tooling
06-2305-00 & 06-2305-01	For optional bearing removal and refitting tooling



Torquemeters Limited

Ravensthorpe, Northampton, NN6 8ET, United Kingdom.

Telephone: +44 (0)1604 770232 Fax: +44 (0)1604 770778

email: info@torquemeters.com www.torquemeters.com

Torquemeters LIMITED
high performance test & measurement systems

Coupling Specification

Recommended Coupling	TORDISC LM230
Shaft End Type	Splined DIN 5480 – 50 x 2 x 24 x 7H 8f
Shaft Nominal Diameter	50mm

Bearing Lubrication Requirements

Lubrication type	Synthetic Grease
Grease type	Lubcon L182 Grease
Grease quantity	1.7 ml

Cartridge Style

ET2303 supplied as a non cartridge style torque meter, refer to GDS01 Sheet Section 3

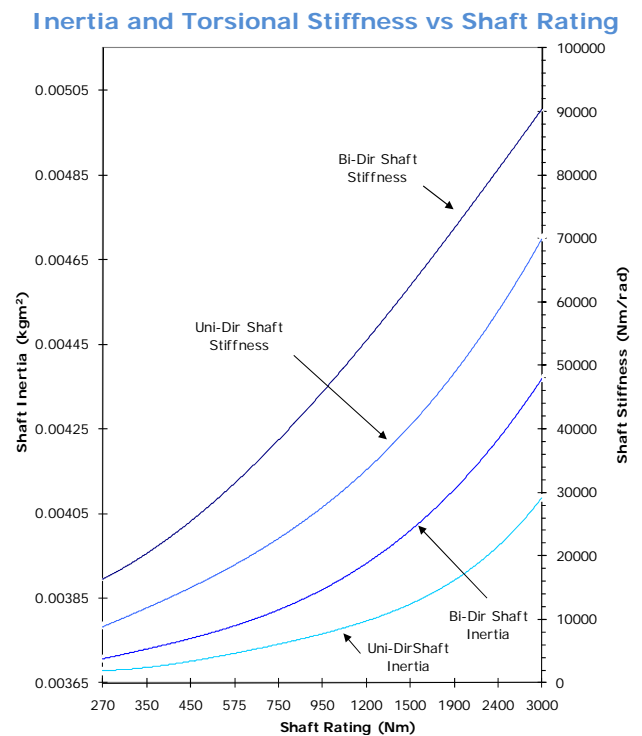
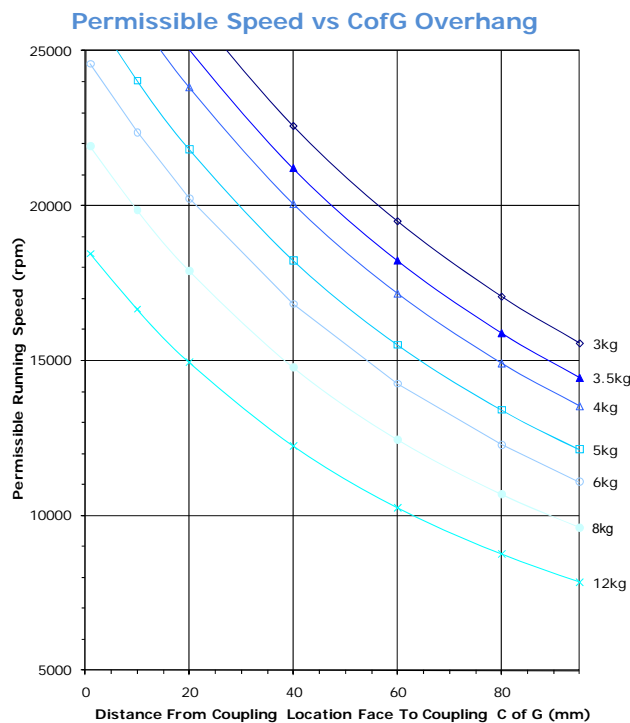

Please refer to Technical Data Sheet (TDS01) for details of Torquetronic Torquemeter phase shift system.
Please refer to Generic Data Sheet (GDS01) for details of Torquemeter options.